

CONTINUUM INDUCTION HOBS

TECHNICAL INFORMATION

MODEL NUMBER	DTi749V	DTi789V	DTi853X
Frame	Bevelled edge	Bevelled edge	Stainless
Width (cm)	93	93	65
	CONTINUUM	CONTINUUM	CONTINUUM
ZONE SPECIFICATIONS			
Induction	4	3	Zoneless
Continuum (40 x 23cm)	1 area / 2 zones	1 area / 2 zones	2 areas / 1-4 split
Continuum (40 x 23cm) (kW)	4.6	4.6	4.6 + 4.6
Front right power (kW)	3.2		
Front right width (cm)	21		
Right power (kW)		3.2	
Right width (cm)		23	
Back right power (kW)	2.2		
Back right width (cm)	16		
Centre power (kW)	4.6	2.2	
Centre width (cm)	28	16	
HOB FEATURES			
Number of power levels	15	15	15
Control type	Touch	Touch	Touch
Control position	Front	Front	Front
Direct access (power levels per zone)	4 / 8 / 15	5 / 6 / 13	•
Boost function	•	•	•
Number of timers	5 x 99 minutes	4 x 99 minutes	4 x 99 minutes
Start control function	•	•	•
Preset functions	•	•	•
SAFETY FEATURES			
Residual heat / hob indicators	•	•	•
Child lock	•	•	•
Auto-safety shut off	•	•	•
Anti-overflow	•	•	•
Anti-overheat	•	•	•
Automatic pan detection	•	•	•
Small object detection	•	•	•
Cleaning lock	•	•	•
Control panel lock	•	•	•
Electronic power monitor	•	•	•
DIMENSIONS			
Aperture H / W / D (mm)	59 x 900 x 490	64 x 900 x 410	64 x 560 x 490
Appliance W / D (mm)	930 x 510	930 x 440	650 x 520
Packed H / W / D (mm)	130 x 1075 x 595	130 x 1075 x 595	135 x 770 x 600
Net weight (kg)	17.5	18	15
Gross weight (kg)	19.5	20	16
ELECTRICAL CONNECTION			
Electric power (kW)	11.8	7.2	9.2
Supplied with cable	Yes (2)	Yes	Yes
Electrical connection	220-240 / 50Hz (double)	220-240 / 50Hz	220-240 / 50Hz
Fuse rating (amps)	20 + 32	32	40

CONTINUUM INDUCTION HOBS TECHNICAL DRAWINGS

DTi749V

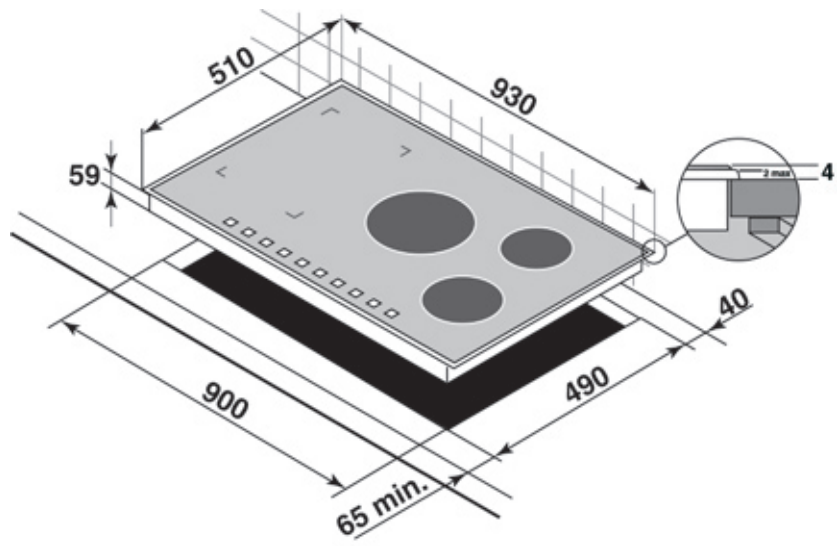

DTi789V

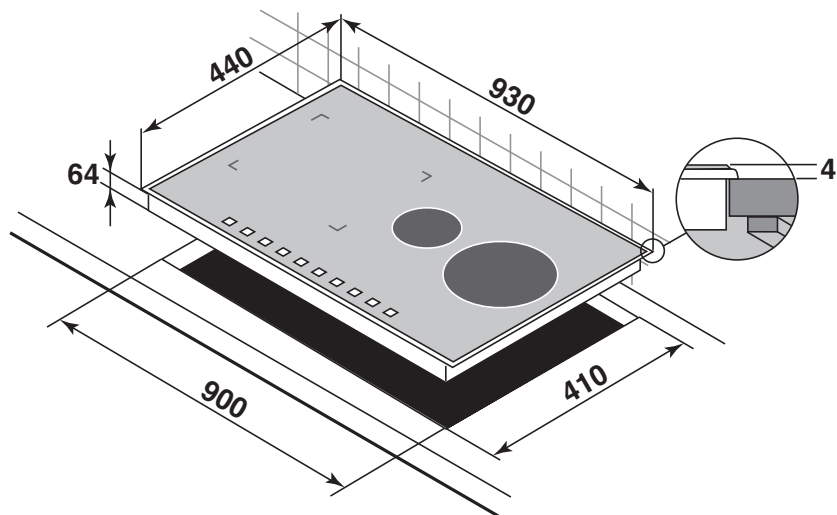

DTi853X

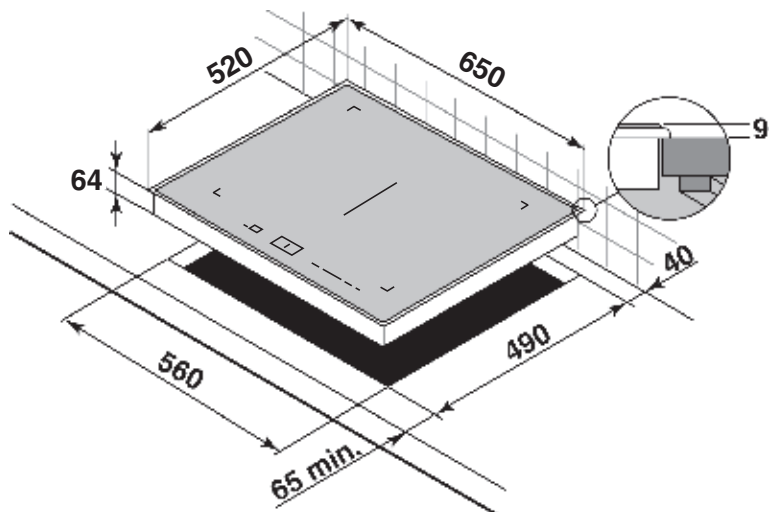

INDUCTION HOBS

TECHNICAL INFORMATION

MODEL NUMBERS	DTi708V	DTi705W	DTi704V	DTi704X	DTi714V
Frame	Bevelled edge	White	Bevelled edge	Stainless	Bevelled edge
Width (cm)	77	65	63	65	58
NUMBER OF COOKING ZONES					
Induction	4	4	4	4	4
POWER / DIAMETER OF ZONES					
Front right power (kW)		2.2	2.0	2.0	2.0
Front right width (cm)		16	16	16	16
Front left power (kW)		2.8	2.8	2.8	2.8
Front left width (cm)		18	18	18	18
Back right power (kW)		3.2	3.1	3.1	3.1
Back right width (cm)		23	21	21	21
Back left power (kW)		2.8	2.8	2.8	2.8
Back left width (cm)		18	18	18	18
Front centre power (kW)	2.2				
Front centre width (cm)	16				
Back centre power (kW)	2.8				
Back centre width (cm)	18				
Right power (kW)	3.2				
Right width (cm)	23				
Left power (kW)	3.2				
Left width (cm)	23				
CONTROLS					
Power levels	15	15	15	15	9
Direct access levels per zone	4 / 8 / 15	4 / 8 / 15	4 / 8 / 15	4 / 8 / 15	
Boost function	•	•	•	•	
Number of timers	4	4	4	4	4
Start control function	•	•			
Programmable memory	•	•	•	•	
SAFETY FEATURES					
Residual heat / hob indicators	•	•	•	•	•
Child lock	•	•	•	•	•
Auto-safety shut off	•	•	•	•	•
Anti-overflow	•	•	•	•	•
Anti-overheat	•	•	•	•	•
Automatic pan detection	•	•	•	•	•
Small object detection	•	•	•	•	•
Cleaning lock	•	•	•	•	•
Control panel lock	•	•	•	•	•
Electronic power monitor	•	•	•	•	•
DIMENSIONS					
Built-in H / W / D (mm)	59 x 750 x 490	59 x 560 x 490	59 x 560 x 490	59 x 560 x 490	59 x 560 x 490
Overall H / W / D (mm)	770 x 510	650 x 520	580 x 510	650 x 520	580 x 510
Packed H / W / D (mm)	160 x 945 x 600	135 x 770 x 600	135 x 770 x 600	135 x 770 x 600	135 x 770 x 600
Net weight (kg)	15	14	14	14	14
Gross weight (kg)	16	15	15	15	15
INSTALLATION					
Electric power (kW) / gas power	7.2	7.2	5.9	5.9	5.9
Supplied with cable	Yes	Yes	Yes	Yes	Yes
Electrical connection	220-240 / 50Hz	220-240 / 50Hz	220-240 / 50Hz	220-240 / 50Hz	220-240 / 50Hz
Fuse rating (amps)	32	32	32	32	32

INDUCTION HOBS
TECHNICAL DRAWINGS

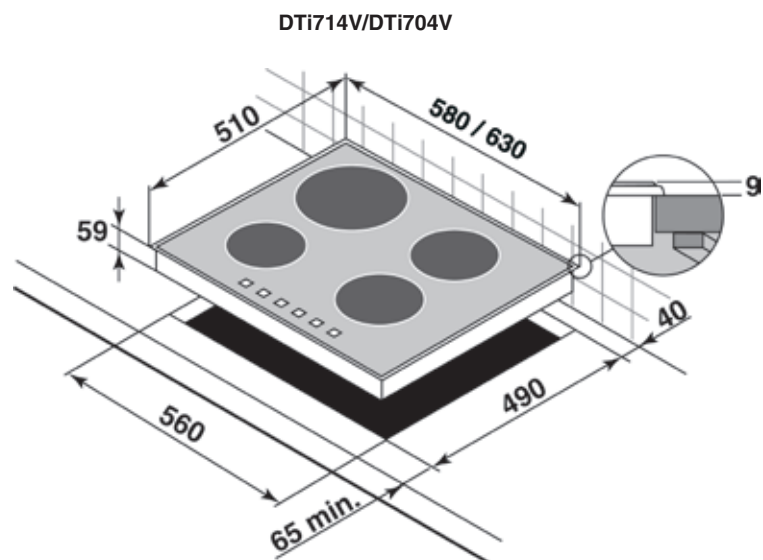
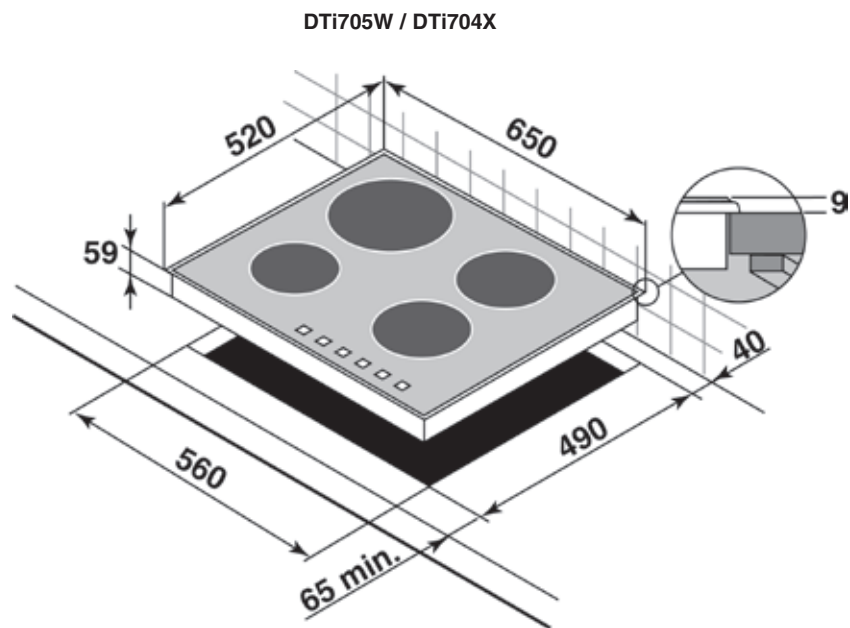
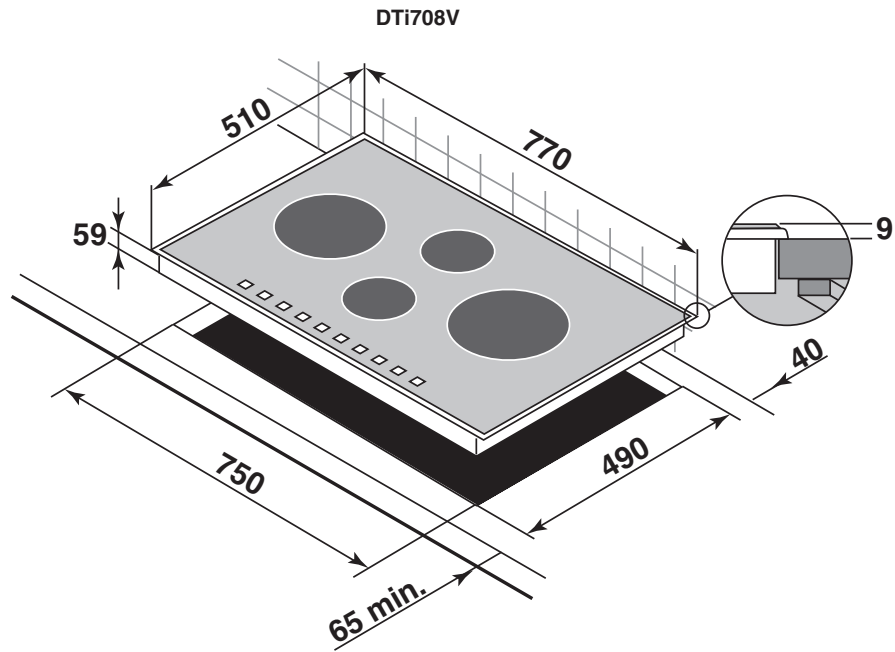

CERAMIC HOBS

TECHNICAL INFORMATION & DRAWINGS

MODEL NUMBER		DTV720J
Frame		Frameless
Width (cm)		63
Control type		Touch control
ZONE SPECIFICATIONS		
Number of zones		4
Speedring		4
Zone type		Ceramic
Front right power (kW)		Speedring 1.2
Front right width (cm)		16.5
Front left power (kW)		Speedring 1.2
Front left width (cm)		16.5
Back right power (kW)		Speedring 2.5
Back right width (cm)		23
Back left power (kW)		Speedring 2.0
Back left width (cm)		21.5
HOB FEATURES		
Number of power levels		17
Control position		Front
Number of timers		4 x 99 minutes
Direct access levels per zone		2
Preset functions		Yes
SAFETY FEATURES		
Residual heat indicators		•
Child lock		•
Auto-safety shut off		•
Anti-overflow		•
Anti-overheat		•
DIMENSIONS		
Built-in H / W / D (mm)		59 x 560 x 490
Overall W / D (mm)		630 x 510
Packed H / W / D (mm)		135 x 600 x 750
Net weight (kg)		9
Gross weight (kg)		10
ELECTRICAL CONNECTION		
Electric Power (kW)		6.9
Supplied with cable		Yes
Electrical connection		220-240 / 50Hz
Fuse rating (amps)		32

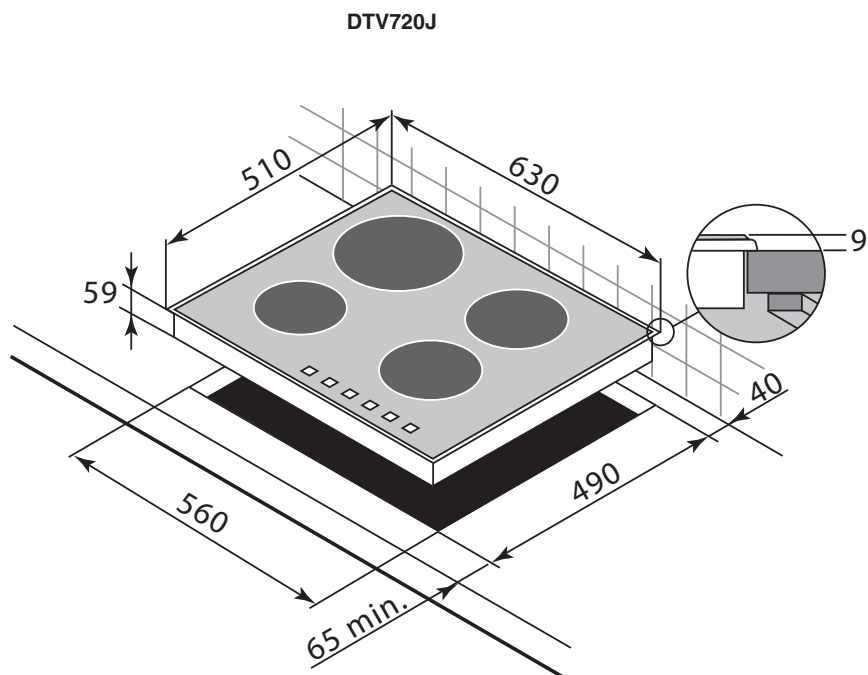

MODULAR HOBS

TECHNICAL INFORMATION & DRAWINGS

MODEL NUMBER	DTi741X	DTi732X	DTG708X	DTG738X	DTE768X
Frame	Stainless	Stainless	Stainless	Stainless	Stainless
Width (cm)	38	38	38	38	38
ZONE SPECIFICATIONS					
Zone type	Induction	Induction wok	Gas on glass	Gas on glass	Teppan Yaki
Number of cooking zones	1 x Continuum	1	1	2	1
Zone power (kW)	4.0	3.0	6.0	0.85	2.5
Front specification	40 x 30cm	Full	Triple crown	Auxiliary	
Rear power (kW)				3.6	
Rear specification				Triple crown	
HOB FEATURES					
Number of power levels	15	9	9	9	
Control type	Touch control	Touch control	Touch control	Touch control	Rotary
Control position	Front	Front	Front	Front	Front
Pan supports	n/a	n/a	Cast iron	Cast iron	n/a
Integrated Ignition	n/a	n/a	•	•	
Electronic timer	1 x 99	1 x 99	1 x 99	1 x 99	
SAFETY FEATURES					
Flame failure safety cut off	n/a	n/a	•	•	n/a
Child lock	•	•	n/a	n/a	n/a
Automatic pan detection	•	•	n/a	n/a	n/a
Anti-overflow safety	•	•	•	•	n/a
Auto-safety shut off	•	•	•	•	n/a
Residual heat indicators	•	•	•	•	n/a
Emergency stop	n/a	n/a	•	•	n/a
Automatic re-ignition	n/a	n/a	•	•	n/a
Heat indicators	n/a	n/a	n/a	n/a	•
Anti-overheat	•				
Small object detection	•				
Control lock	•				
Cleaning lock	•				
Electronic power monitor	•				
DIMENSIONS					
Aperture H / W / D (mm)	59 x 340 x 490	117 x 340 x 490	51 x 340 x 490	51 x 340 x 490	82 x 340 x 490
Appliance H / W / D (mm)	59 x 380 x 520	117 x 380 x 520	51 x 380 x 520	51 x 380 x 520	82 x 380 x 520
Packed H / W / D (mm)	210 x 480 x 600	330 x 480 x 580	210 x 480 x 580	210 x 480 x 580	235 x 400 x 545
Net weight (kg)	16	8	9	8	11.6
Gross weight (kg)	17	10	10	9	12.6
ELECTRICAL CONNECTION					
Electric Power (kW)	4.5	3			2.5
Supplied with cable	Yes	Yes	Yes	Yes	Yes
Electrical connection	230V / 50Hz	230V / 50Hz	230V / 50Hz	230V / 50Hz	230V / 50Hz
Fuse rating (amps)	20	16	13	13	13

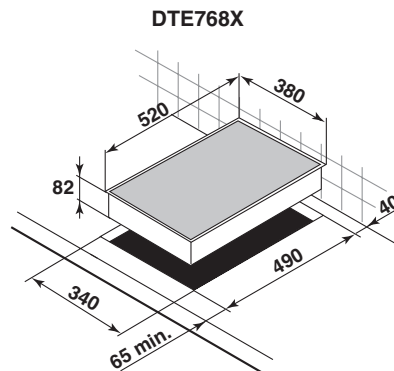
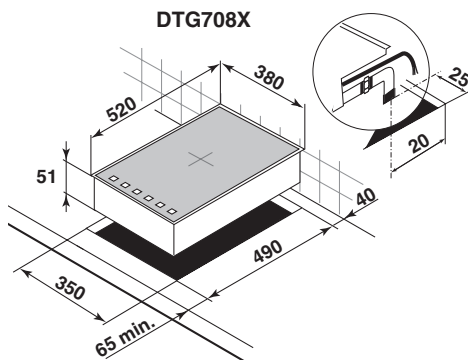
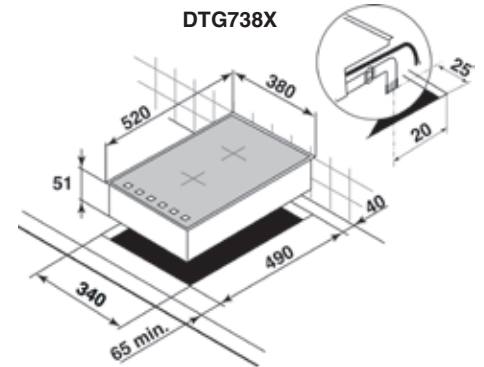
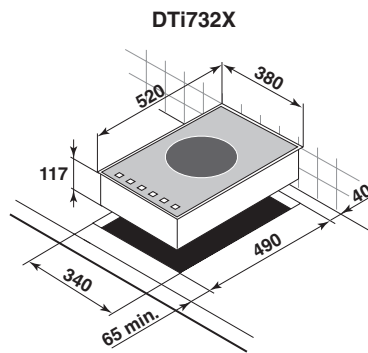
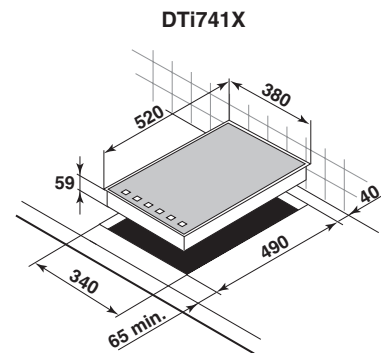

Please note: if planning to install Modular Hobs side by side, a minimum distance of 75mm should be observed between each appliance.

GAS HOBS

TECHNICAL INFORMATION

MODEL NUMBER	DTG795X	DTG775X	DTG764X	DTE714X/B/W	DTE712X
Frame	Stainless design	Stainless design	Stainless design	Stainless design	Stainless design
Width (cm)	90	72	60	60	60
ZONE SPECIFICATIONS					
Zone type	Gas on glass	Gas on glass	Gas on glass	Gas	Gas
Number of cooking zones	5	5	4	4	4
POWER / DIAMETER OF ZONES					
Front right power (kW)	1.0	1.0	1.0	1.0	0.85
Front right type	Auxiliary	Auxiliary	Auxiliary	Auxiliary	Auxiliary
Front left power (kW)	1.75	1.75	3.8	3.8	3.1
Front left type	Semi rapid	Sem rapid	Rapid	Ultra wok	Ultra rapid
Back right power (kW)	1.75	1.75	1.75	3.0	2.25
Back right type	Semi rapid	Semi rapid	Semi rapid	Rapid	Rapid
Back left power (kW)	3.0	3.0	1.75	1.75	1.5
Back left type	Rapid	Rapid	Semi rapid	Semi rapid	Semi rapid
Wok power (kW)	3.8	3.8			
CONTROLS					
Control type	Rotary	Rotary	Rotary	Rotary	Rotary
Control position	Front	Front	Front	Front	Side
Pan supports	Yes	Yes	Yes	Yes	Yes
SAFETY FEATURES					
Integrated ignition	•	•	•	•	•
Gas safety cut off	•	•	•	•	•
DIMENSIONS					
Built-in H / W / D (mm)	47 x 860 x 480	47 x 660 x 480	47 x 560 x 480	47 x 560 x 480	34 x 560 x 480
Overall W x D (mm)	900 x 510	720 x 510	600 x 510	600 x 510	600 x 510
Packed H / W / D (mm)	148 x 963 x 558	148 x 783 x 558	148 x 663 x 558	148 x 663 x 558	148 x 663 x 558
Net weight (kg)	20	18.3	13	15	15
Gross weight (kg)	21	19	14	16	16
INSTALLATION					
Gas power	11.3	11.3	11.3	11.3	11.3
Supplied with cable	Yes	Yes	Yes	Yes	Yes
Electrical connection	220-240 / 50Hz	220-240 / 50Hz	220-240 / 50Hz	220-240 / 50Hz	220-240 / 50Hz
Fuse rating (amps)	13	13	13	13	13

GAS HOBS

TECHNICAL DRAWINGS

DTG795X

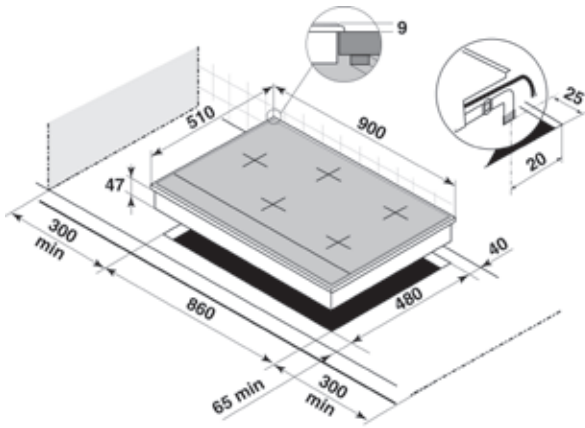

DTG775X

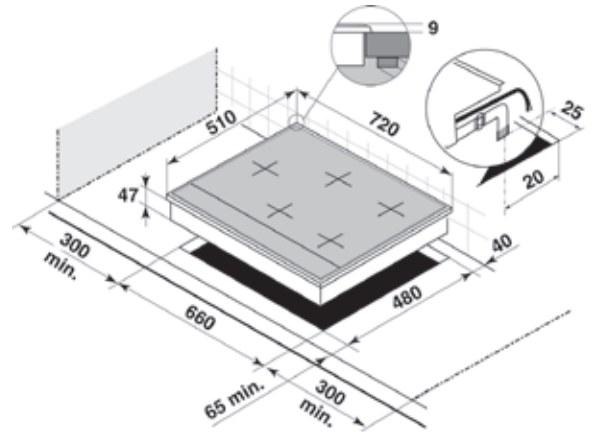

DTG764X

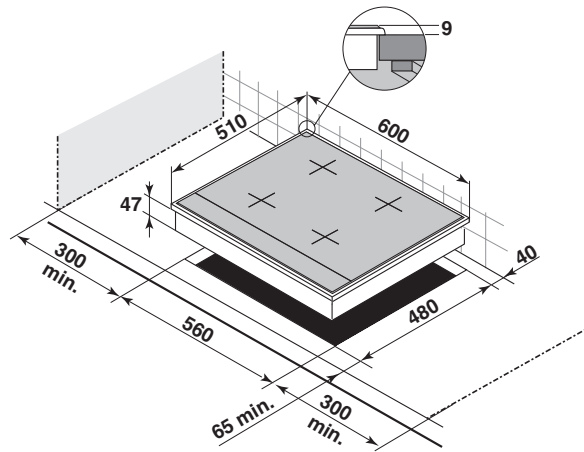

DTE714X

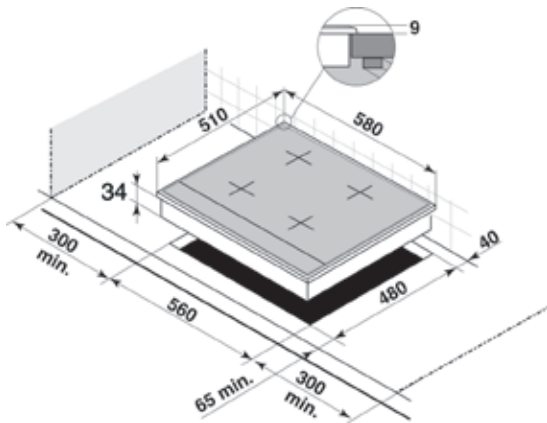

DTE712X

