

FR GUIDE D'UTILISATION
CS NÁVOD K POUŽITÍ
DA BRUGERVEJLEDNING
DE BETRIEBSANLEITUNG
EN USER GUIDE

Four
Trouba
Ovn
Backofen
Oven

De Dietrich 



Dear Customer,

*You have just acquired a **DE DIETRICH** oven and we would like to thank you.*

Our research teams have created this new generation of appliances for you. Their quality, appearance, functions and technological advances make them exceptional products, showcases of our unique know-how.

*Your new **DE DIETRICH** oven will blend harmoniously into your kitchen and perfectly combine cooking performance and ease of use. We wanted to offer you a product of excellence.*

*In the line of **DE DIETRICH** products, you will also find a wide range of cookers, hobs, ventilation hoods, dishwashers, and refrigerators, all of which can be built in and coordinated with your new **DE DIETRICH** oven.*

Of course, in an ongoing effort to better satisfy your demands with regard to our products, our after-sales service department is at your disposal and ready to listen in order to respond to all of your questions and suggestions (contact information at the end of this booklet).

You can also log onto our site:

www.dedietrich-electromanager.com where you will find our latest new ideas and useful additional information.

DE DIETRICH
Setting New Values

www.dedietrich-electromanager.com

As part of our commitment to constantly improving our products, we reserve the right to make changes to them based on advances to their technical, functional and/or aesthetic properties.



Important:

Before installing and using your appliance, please read this Installation and Usage Guide carefully, as it will allow you to quickly familiarise yourself with its operation.

1 / DESCRIPTION OF YOUR APPLIANCE	
• Introduction to your oven _____	4
• Swivelling fascia _____	5
• Description of controls _____	5
2 / USING YOUR APPLIANCE	
• Cooking _____	6
• Using the programmer	
◦ How to set the time _____	7
• Using the “EXPERT” function _____	8
• Using the “COOKING GUIDE” function _____	14
• Using the “ICS” function _____	16
• Using the “LOW TEMPERATURE” function _____	24
• Using the “INFORMATION” function _____	26
◦ Timer _____	26
◦ Cleaning _____	27
◦ Time / Date _____	28
◦ Lock controls _____	28
◦ Sound / Beep! _____	28
◦ Consumption _____	29
◦ Languages _____	29
3 / AFTER-SALES SERVICE	
• Service calls _____	31

• **INTRODUCTION TO YOUR OVEN**

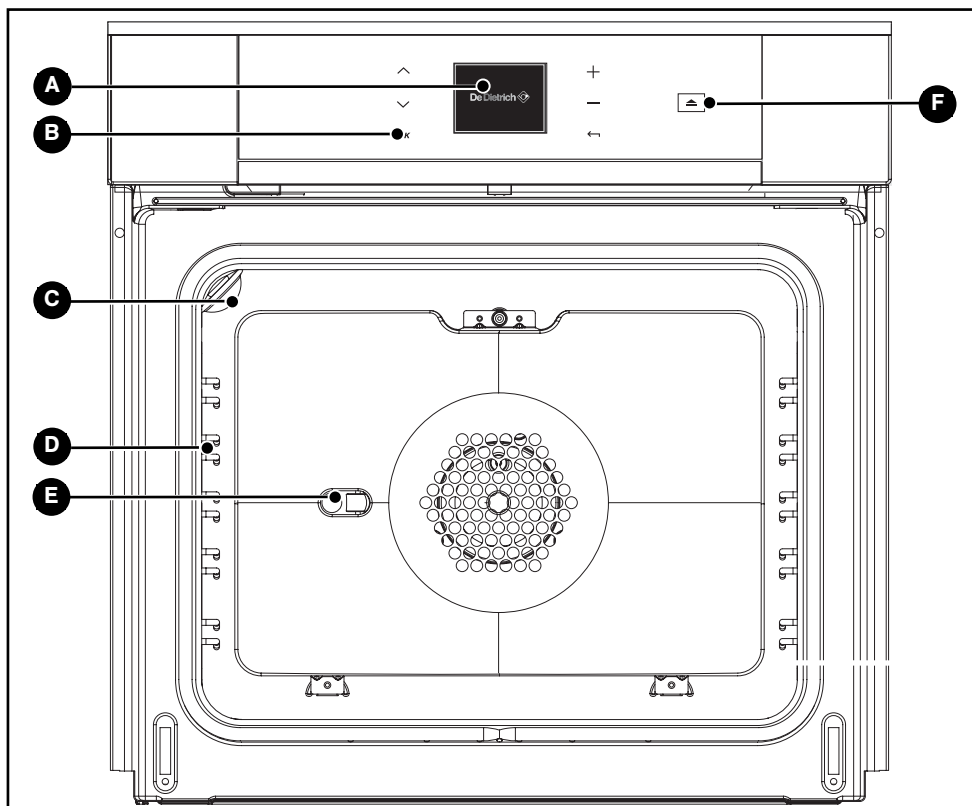

A Programmer

B Control buttons

C Lamp

D Wire shelf supports

E Hole for rotisserie

F Button for electrically-powered swivelling panel

(DEPENDENT ON THE MODEL)

• SWIVELLING FASCIA

(DEPENDING ON THE MODEL)

To facilitate reading and using your programmer, the panel swivels to a 30° angle.

Mechanical model (FIG.1)

Open and close by pressing the centre of the panel under the control buttons.

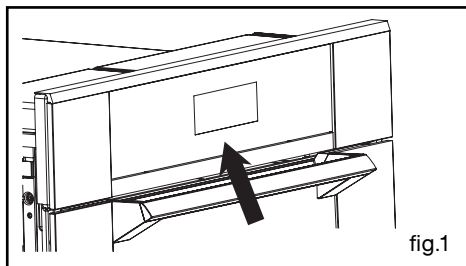

Electrically-powered model (FIG.2).

Open and close by pressing the  button (warning: do not hinder opening).

NOTE: The "Pyrolysis" function blocks the panel in its initial position (open or closed).

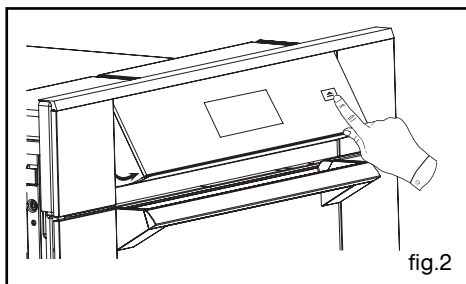

• DESCRIPTION OF CONTROLS

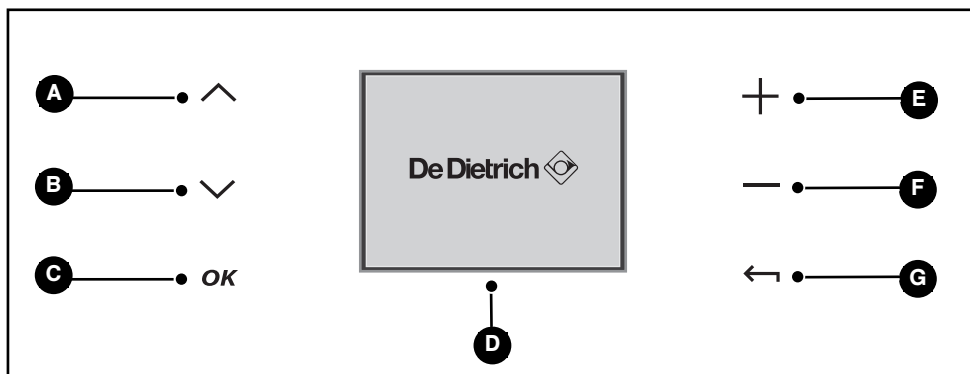

A Selection touch control (at the top)

B Selection touch control (at the bottom)

C Validation touch control

D Display

E } Adjustment buttons (+ or -)
F } for time / temperature

G "Go back" touch control

• **COOKING**

This oven allows you to access three different types of programming depending on the knowledge you have about preparing the recipe in question:

- A recipe for which you know all the settings (you will choose on your own the type of cooking, temperature and cooking time): select the **"EXPERT" function** directly by pressing the selection button.

- A recipe for which you need the oven to help you (simply choose the type of food from a list and the weight; the oven will select the most suitable settings: temperature, cooking time, type of cooking): select the **function "COOKING GUIDE"**.

- A recipe managed automatically by the oven: you will select from a list of the 12 most popular dishes, the one you would like to cook (temperature, cooking time and cooking program are defined by the oven): select the **"ICS" function** (Intelligent Cooking System).

- A recipe by a specific program managed electronically by the oven to give you an incomparably tender result for meat and exceptional flavour; the ovenware supplied with the oven to lift the meat and allow an ideal circulation of hot air around it (see recommendations for using this). Guarantee of tenderness without drying out, easy slicing, edges not overcooked, meat juices retained.

Select the **"LOW TEMPERATURE" function**.

• USING THE PROGRAMMER

• How to set the time

- Press **OK** (fig.1).
- Select "Information" by pressing **∨** (fig.2).

- Confirm by pressing **OK**.

- Select line "3. Time/Date" by pressing **∨** (fig.3).

Time/date display

Day display

- Confirm by pressing **OK**.

Set it by pressing the touch controls **+** or **-** (fig.4).

- Press **∨** to display:

- Set by pressing the touch controls **+** or **-**.

- Confirm by pressing **OK**.

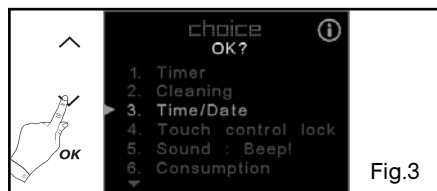
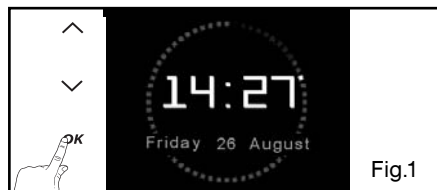

• USING THE “EXPERT” FUNCTION

This function lets you set all the cooking settings yourself: temperature, type of cooking, cooking time

- Confirm by pressing **OK**. You access the “Expert” screen (fig.1).

- Confirm by again pressing **OK**.

- Select the cooking type from the following list by pressing **∨** (fig.2).

(For this choice, refer to the attached cooking guide):

1. Fan

2. Combined heat

3. Eco heat

4. Conventional

5. Turbo - grill

6. High grill

7. Medium grill

8. Keep warm

9. Defrosting

10. Memory

- Confirm your selection by pressing **OK**.



Fig.1



Fig.2

• TEMPERATURE

Based on the type of cooking you already selected, the oven will recommend the ideal cooking temperature. This temperature can be adjusted as follows:



- Press the touch control + or - (fig.1) and select your desired temperature.

- Confirm your selection by pressing **OK**.





Fig.1

• COOKING TIME AND COOKING FINISH TIME

You can enter the cooking time for your dish by selecting the option  (fig.1) by pressing .

Enter the cooking time by pressing + (fig.2).
- Confirm your selection by pressing **OK**.

When you set the cooking time, the cooking finish time (option ) increases automatically (fig.2). You can change this end of cooking time if you want to delay the programme start. In this case, select the case  and proceed in the same way to set the cooking time (fig.3). Once you have selected the cooking end time, press **OK** to confirm.

Your oven goes into standby mode ( symbol in the display) until cooking starts (cooking end time - total cooking time)

Note: You may opt not to select a cooking time. In this case, leave the cooking time and cooking finish time blank and go directly to "OK". Confirm to start cooking. The oven will turn off when you press any touch control when you think your dish has been cooking long enough, then select "Stop" and press **OK**.

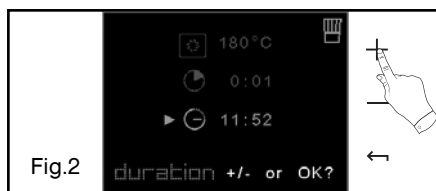

• USING THE “OPTION BIOGRILL +” FUNCTION

It is not active during the following functions: Eco, fan grill, keep warm, high grill and medium grill.

After setting your cooking time, if you press “OK” once, the oven will suggest “option biogrill+” (fig.1).

This function allows you to combine the chosen cooking method with a function that “browns” your dish at the end of cooking; this can be accomplished by turning on the grill for the last five minutes of the programme.

Select “yes” by pressing the  touch control, then confirm “OK”.

The following appears in the screen:

Memorisation of your cooking settings.

Choose to record your settings or not, then confirm by “OK” (see following chapter).

Confirm “OK” again, then start the cooking (fig.2).

To avoid overly fast browning, do not place dishes too close to the grill. Use the 1st or 2nd shelf support (counting from the bottom).

Programming example:

French onion soup:

- Select a cooking sequence (eg, combined heat)

- Select the temperature (eg, 180°C)

- Select a cooking time (eg, 25 mins)

- Select the program “biogrill +”

The broth will heat for 20 minutes and the gratin will be formed during the remaining 5 minutes.



Fig.1



Fig.2

• USING THE “MEMORY” FUNCTION

- Memorise a cooking.

The MEMORY function makes it possible to memorise 3 cooking modes that you have tried out with the “Expert” function. Thus you no longer have to go to the trouble of always entering the same data. With identical dishes and quantities prepared, you will always get the same result.

When you finish entering your cooking settings, you will be asked if you want to memorise them (fig.1).

Select “yes” by pressing the  touch control, then confirm “OK”.



The screen then offers a choice between recording the parameters in an empty memory cell or replacing a memorised programme of your choice with the new parameters (fig.2).

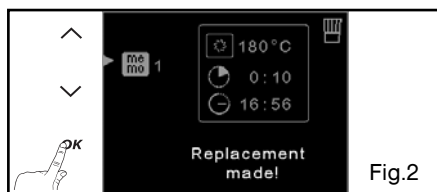

- Use a cooking recorded in the “Memory” function

Go to the menu item “Expert”.

- Confirm “OK”.

- Using the  touch control, scroll through the functions until you get to “Memory” (fig.1).

- Select the memory depending on the cooking you want and confirm “OK”.



**FAN**

(recommended temperature **180°C** min 35°C max 235°C)

- Cooking controlled by the heating element located at the back of the oven by the fan.
- Rapid temperature increase: Some dishes can be placed in the oven while it is still cold.
- Recommended for keeping white meat, fish and vegetables moist.

For cooking multiple items on up to 3 levels.

**COMBINED HEAT**

(recommended temperature **205°C** min 35°C max 275°C)

- Cooking controlled by the upper and lower heating elements and by the fans.
- Three combined sources of heat: a lot of heat from the bottom, a little circulating heat and a bit from the grill.
- Recommended for quiches, pies, wet fruit tarts, placed preferable on an earthenware dish.

**ECO HEAT**

(recommended temperature **200°C** min 35°C max 275°C)

- Cooking is controlled by the upper and lower heating elements.
- This position allows for energy savings while preserving the quality of the cooking.
- The ECO position is used for energy label performance.
- All types of cooking are done **without preheating**.

**CONVENTIONAL**

(recommended temperature **240°C** min 35°C max 275°C)

- Cooking is controlled by the upper and lower heating elements with no fan.
- Requires preheating before placing the dish in the oven.
- Recommended for slow, gentle cooking: **rich game...** For retaining the juices in **red meat roasts**. For simmering in a covered casserole, dishes that were begun on the hob (**coq au vin, stew**).

**TURBO GRILL + SPIT**

(recommended temperature **200°C** min 180°C max 230°C)

- Cooking controlled, alternately, by the upper element and by the fan.
- Preheating is unnecessary. Roasts and poultry are juicy and crispy all over.
- The spit keeps turning until the door is opened.
- Slide the drip tray onto the bottom shelf support.
- Recommended for all poultry and roasts on the spit, for cooking leg joints thoroughly, and cuts of beef. To keep fish steaks moist.



HIGH GRILL + SPIT

(recommended positions **4** - min 1 - max 4)

- Cooking is done by the upper element without the fan.
- Preheat the oven for 5 minutes.
- Recommended for browning vegetable dishes, pasta, fruit, etc. placed under the grill.



MEDIUM GRILL + SPIT

(recommended positions **2** - min 1 - max 4)

- Cooking is done by the upper element.
- Preheating is unnecessary. Roasts and poultry are juicy and crispy all over.
- The spit keeps turning until the door is opened.
- Slide the drip tray onto the bottom shelf support.
- Recommended for all **roasts** on the spit, for sealing and thoroughly cooking **leg, cuts of beef**. To keep **fish steaks** moist.



KEEP WARM

(recommended temperature **80°C** min 35°C max 100°C)

- This position allows you to keep your dishes hot by occasional heating from the bottom of the oven along with the fan.
- Recommended for letting dough rise for bread, brioche, kugelhopf... without exceeding 40°C (plate warming, defrosting).



DEFROSTING

(recommended temperature **30°C** min 30°C max 50°C)

- Dishes are defrosted by a limited amount of heat and the fan.
- Ideal for delicate dishes (fruit tart, custard pie, etc).
- Meat, buns, etc, are defrosted at 50°C (meat should be placed under the grill with a dish underneath to catch drips from the defrosting which are not edible).

• USING THE “COOKING GUIDE” FUNCTION

This function selects for you the appropriate cooking parameters based on the food being prepared and its weight.

- Press “OK” (fig.1).

The oven then suggests different food categories.

- Press  to select from the categories offered (fig.2):

- Confirm your selection by pressing “OK”.

- Then select the specific dish to prepare and confirm by pressing “OK” (fig.3).

Once you have selected a food category, the oven will ask you to enter its weight (field  fig.4) or the material your cookware is made of (aluminium, porcelain, etc) in the case of cakes, quiches, tarts and vegetables or the size of the food, for example: bun.

- Enter the weight or cookware type and the oven will automatically calculate and display the ideal cooking time. If you wish, you can change the cooking finish time by selecting the field “” and selecting the new end of cooking time.

- Place your dish in the oven on the recommended shelf support level (from 1 at the bottom to 5 at the top) (fig.5).

- Confirm by pressing “OK”.

The oven begins heating.

-The oven beeps and turns off when the cooking time is finished and your screen then indicates that the dish is ready.



Fig.1



Fig.2



Fig.3



Fig.4



Fig.5

No. 1 WHITE MEAT:

No.1	chicken (dish)
2	chicken (spit)
3	duck
4	turkey leg
5	rabbit
6	goose
7	guinea fowl
8	pork loin
9	pork fillet
10	terrine
11	veal roast

No. 2 RED MEAT:

No.1	shoulder of lamb
2	leg of lamb
3	saddle of lamb
4	beef medium done
5	beef rare
6	pheasant
7	hare

No. 3 FISH:

No.1	pike
2	bream
3	whiting
4	roast fish
5	salmon
6	fish terrine
7	trout

No.4 VEGETABLES:

No.1	endives
2	vegetable flans
3	potato gratin
4	lasagna
5	stuffed peppers
6	stuffed tomatoes

No. 5 TARTS/QUICHES:

No.1	quiche
2	short crust
3	flaky crust
4	cheese tart
5	rising crust
6	fruit tart
7	meat pie
8	soufflé
9	bread

No. 6 CAKES:

No.1	bun
2	cake
3	puff pastry
4	chocolate cake
5	yoghurt cake
6	genoese
7	kugelhof
8	meringues
9	pound cake
10	biscuits/cookies

• ADDITIONAL DETAILS FOR “COOKING GUIDE” COOKING

All the cooking is done WITHOUT preheating the oven.

COOKING PROGRAMME: CAKES/TARTS:

Choosing the type of baking mould:

Aluminium: Coloured anti-stick moulds and flexible silicone moulds are very suitable for moist batters (quiches or fruit tarts).

COOKING PROGRAMME: TERRINES

Place the terrine in a double-boiler (set it in a larger dish that is half-full of boiling water).

• USING THE “ICS” FUNCTION

The ICS (Intelligent Cooking System) function will completely simplify cooking for you because the oven will automatically calculate all the cooking parameters (temperature, cooking time, cooking mode) based on the selected dish thanks to its electronic sensors located in the oven that constantly measure the moisture level and temperature variations.

OPERATING THE ICS FUNCTION:

This cooking mode takes place in two phases:

1) a data search phase during which the oven begins heating and determines the ideal cooking time. This phase lasts between 5 and 40 minutes depending on the dish.

- Press the “ICS” button (fig.1).

The oven offers a choice of 12 dishes:

- **Pizza**
- **Savoury tart**
- **Roast beef** (rare, medium or well done)
- **Roast pork**
- **Chicken**
- **Lamb pink** (rare or well done)
- **Fish**
- **Stuffed vegetables**
- **Tart**
- **Cakes**
- **Small biscuits**
- **Soufflé**

- Press ✓ to select your dish (fig.2).

Example: Soufflé 

After selecting your dish, confirm by pressing “OK”.

You can change the cooking finish time before putting your dish into the oven at the recommended shelf level.

- Confirm by pressing the **OK** button to start cooking (fig.3).



• USING THE “ICS” FUNCTION

N.B.: No preheating is required to use the ICS function. Cooking **ABSOLUTELY** must begin in a cool oven. You should wait for the oven to cool down completely before beginning a second cooking programme.

IMPORTANT: Do not open the door during this phase or you may disturb the recording of data.

This search phase is represented by the symbol “~” beside the cooking time (see arrow in fig.1).

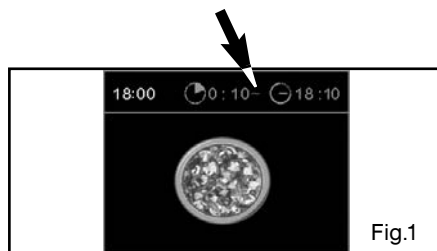

2) a second cooking phase: the oven has calculated the necessary time, the symbol “~” disappears. The remaining cooking time indicated takes into account the cooking time from the first phase. You can now open the door (e.g. to baste a roast).

- The oven beeps and turns off when the cooking time is over and your screen then indicates that the dish is ready.

DELAYED START FUNCTION:

To program a delayed start,

- Select the cooking end function ☹ and change the cooking end time.

PLEASE NOTE: If you want to programme a subsequent ICS cooking cycle, wait until the oven has cooled completely. However, you can use the “Expert” function even if the oven is hot.



Pizza

- Fresh store-bought pizza
- Ready-to-use pizza dough
- Home-made pizza dough
- Frozen pizza



Tarts (savoury)

- Fresh quiches
- Frozen quiches
- Frozen mini-pastry



Roast Beef

- Roast beef (prepared rare)
- ⚠ • Place the roast on the grid using the grid + drip tray assembly.

You can turn it over when the cooking time becomes fixed.



Roast Pork

- Pork roasts
 - Loin
 - Tenderloin



Chicken

- Chickens weighing 1 to 1.7 kg
- Duck, guinea fowl, etc.



Lamb

- Leg of 1kg to 2,500kg
- ⚠ • Place the roast on the grid using the grid + drip tray assembly.

You can turn it over when the cooking time becomes fixed.



Fish

- Whole fish (sea bream, pollock, trout, mackerel, etc.)
- Roasted fish



Vegetables stuffed

- Tomatoes, stuffed peppers & vegetables
- Lasagna (fresh or frozen)
- Shepherd's pie, brandade, etc.



Tarts (sweet)

- Fresh tarts
- Frozen tarts



Cakes

- Home-style cakes: sweet or savoury loaves, pound cake.
- Ready-to-mix batters in packets.



Small Biscuits

- Small individual pastries: cookies, croissants, buns, fruit bread in a mould, croque-monsieur.



Soufflé

- Use a tall mould with straight edges and a diameter of 21cm.

-
- Place it on the grid for a crispy crust (you can place a sheet of parchment paper between the grid and the pizza to protect the oven from cheese drippings).
 - Place the pizza on the baking tray for a soft crust.
-

- Use a non-stick aluminium mould: the crust will be crispy on the bottom.
 - Remove the tray from frozen quiches before placing them on the grid.
-

- Take the roast out of the refrigerator at least one hour before starting the cooking programme:
 - If you prefer meat rare; if you prefer it well done, opt for a traditional cooking function.
 - Trim away as much fat as possible: it causes smoke.
 - At the end of cooking, allow the meat to sit for 7 to 10 minutes wrapped in a sheet of aluminium foil before carving.
-

- Take the roast out of the refrigerator at least one hour before starting the cooking programme: the colder the meat is, the closer it will be to the end of cooking.
 - Use an earthenware dish. Add one to two tablespoons of water.
 - At the end of cooking, allow the meat to sit for 7 to 10 minutes wrapped in a sheet of aluminium foil before carving. Add salt when cooking is finished.
-

- Turnspit cooking: do not forget to place the drip tray on the first shelf support to catch the drippings.
 - Cooking in a dish: Opt for earthenware dishes to avoid splattering.
 - Pierce the skin of poultry to avoid splattering.
-

- Take the meat out of the refrigerator at least one hour before starting the cooking programme:
 - Select a leg that is round and plump rather than long and lean.
 - Wrap the meat in aluminium and let it sit after cooking.
-

- Use this function only for whole fish cooked with herbs and white wine.
(Grilled fish or papillote preparations require that the oven be preheated.)
-

- Properly adjust the dimensions of the dish to the quantity of food to be cooked to avoid juices spilling over.
-

- Use a non-stick aluminium mould:
 - The crust will be crispy on the bottom.
-

- Cakes made in a cake mould, round, square... and always placed on the grid.
It is possible to place two cake moulds side by side.
-

- Small individual cakes made on a pastry tray and placed on the grid.

 Puff pastry must be cooked on "CAKES" to achieve good results.

- Butter the mould and do not touch the inside with your fingers or the soufflé will not rise.
-

Pizza

To prevent cheese or tomato sauce from dripping in the oven, you can place a piece of parchment paper between the grid and the pizza.

Tarts / Quiches

Avoid glass and porcelain dishes: because they are too thick, they extend the cooking time and the bottom of the crust is not crispy. With fruit, the bottom of the tart risks becoming soggy: just add a few spoonfuls of fine semolina, crushed biscuit crumbs, almond powder or tapioca, which will absorb the juice during cooking. With high-water content or frozen vegetables (leeks, spinach, broccoli or tomatoes) you can sprinkle a tablespoon of cornmeal.

Fish

When buying it, it should smell pleasant and not too “fishy”. The body should be firm and rigid and the scales should be firmly attached to the skin; the eyes should be bright and rounded and gills will appear shiny and moist.

Beef / Pork / Lamb

You **must** take all meat out of the refrigerator well before cooking it: cold-hot temperature shocks toughen meat; this way you will produce a roast beef that is golden outside, red inside and warm in the middle. Do not salt before cooking: salt absorbs the blood and dries out the meat. Turn the meat using spatulas: if you pierce the meat the blood drips out. Always let meat sit after cooking for 5 to 15 minutes: wrap it in a sheet of aluminium and place it just inside a warm oven: This allows the blood drawn toward the outside during cooking to return to the middle and moisten the roast.

Use earthenware roasting dishes: glass promotes grease splattering.

Do not cook in the enamelled drip tray.

Avoid piercing the leg of lamb with cloves of garlic as the lamb will lose its juices; instead, slide the garlic in underneath the skin, or bake the unpeeled garlic beside the leg and crush it when it has finished cooking to flavour the gravy; sieve it and serve very hot in a gravy boat.

Pizza Base: 1 pizza crust

*with vegetables: 6 tablespoons tomato sauce + 100g diced courgettes + 50g diced bell peppers + 50g sliced aubergine + 2 small sliced tomatoes + 50g grated gruyere + oregano + salt + pepper.

*with roquefort and smoked bacon: 6 tablespoons tomato sauce + 100g smoked bacon + 100g roquefort in small chunks + 50g walnuts + 60g grated gruyere.

*with sausage and cottage cheese: 200 g drained cottage cheese spread on the crust + 4 sausages, sliced + 150g ham slivers + 5 olives + 50g grated gruyere + oregano + salt + pepper.

Quiches: Base: 1 aluminium mould, diameter 27 to 30 cm

1 ready-to-use short crust pastry

3 beaten eggs + 50 cl heavy cream

salt, pepper, nutmeg.

Various garnishes:

200g precooked larding bacon

or - 1 kg cooked endives + 200g grated gouda

or - 200g broccoli + 100g small bacon pieces + 50g blue cheese

or - 200g salmon + 100g spinach, cooked and drained

Roast beef PARSLEY SAUTERNES Sauce with ROQUEFORT:

Cook 2 tablespoons of sliced shallots in butter until translucent. Add 10 cl Sauternes, let it evaporate. Add 100g Roquefort, let it melt slowly. Add 20 cl liquid cream, salt, pepper. Bring to a boil.

Roast pork Pork with prunes

Ask the butcher to carve a hole through the length of the roast. Stuff 20 prunes inside. Serve sliced with its juices or cold with an endive salad.

Chicken

Stuff it with a good bouquet of fresh tarragon or rub it with a mixture of 6 crushed cloves of garlic with a pinch of coarse salt, and some peppercorns.

Lamb Anchovy sauce:

Puree 100g black olives, 50g capers and 3 anchovies, 1/2 clove of garlic and 10 cl olive oil. Add 10 cl crème fraîche. Serve with sliced leg of lamb.

Fish

Black sea bream with dry cider:

- 1 bream weighing 1.5 kg.
- 500g button mushrooms.
- 2 sour apples.
- 2 shallots.
- 2 tablespoons heavy cream.
- 100g butter.
- 1/2 litre cider. Salt, pepper.

Gut and scale the fish. Place it in a buttered dish on the finely minced shallots and sliced mushrooms. Add the cider, salt and pepper and some cubes of butter. Put it in the oven. In the butter cook the unpeeled quartered apples. When cooking is complete, transfer the fish to a warm dish, strain the juice and deglaze the dish with the cream. Add the cream to the juice, serve with apples and mushrooms.

Stuffed vegetables

Leftovers from pot au feu, leg of lamb, pork roasts, and roasted poultry can be finely chopped for an excellent base.

Flaky praline apple tart

- 1 flaky pastry crust rolled and pricked with a fork.
- 200 ml cream brought to a boil with a vanilla pod.
- 2 beaten eggs with 30g sugar, add the cooled cream.
- 2 apples cut into cubes rolled in 70g crushed pralines.

Add cream and apples to crust. Place in the oven.

Pound cake with citrus fruits

- Caramel: 20 lumps of sugar (200g).
- Cake: 4 eggs.
- 200g granulated sugar.
- 200g flour.
- 200g good butter.
- 2 teaspoons baking powder.
- Fruits: 1 small tin of citrus fruits in syrup.

Drain the fruit. Prepare a caramel icing. When it has taken on colour, turn it out into a cake pan; tip it around to distribute the caramel. Let cool. In the bowl of an electric blender, mix the softened butter with the sugar. Add the whole eggs one at a time, then the sifted flour. Finish with the baking powder. Place the citrus sections in a flower pattern on the caramel icing. Pour in the batter. Place in the oven on the "CAKES" setting. Unmould in a pretty dish and serve cold. Other fruits can be used, such as apples, pears or apricots.

Individual chocolate cakes

- 12 individual aluminium ramekins.
- 60g butter.
- 200g bitter chocolate (more than 50% cocoa).
- 100g caster sugar.
- 4 eggs.
- 1 packet of baking powder.
- 70g sifted flour.

Melt the chocolate with the butter over very low heat. Work the egg yolks into the sugar until the mixture becomes smooth. Add the flour, melted chocolate with butter and finish with the baking powder. Beat the egg whites into stiff peaks and gently fold them into the mixture. Lightly butter and flour the aluminium ramekins and pour the batter into them (without dripping any on the edges). Place the ramekins on the baking tray and choose the “BISCUITS” mode. Unmould and let cool on a grid. Serve with vanilla crème anglaise or coconut ice cream.

Soufflés

Béchamel sauce base:

- 1/2 litre milk.
- 60g flour.
- 100g butter.
- 4 egg yolks + whites beaten into stiff peaks.
- salt, pepper, nutmeg.

Depending on the type of soufflé, you will add 150g shredded gruyere or 1 kg cooked, chopped spinach or 1 kg cooked, chopped cauliflower or 150g shredded leftover cooked fish or 150g chopped ham.

• USING THE “LOW TEMPERATURE” FUNCTION

Cooking absolutely must begin in a “LOW TEMPERATURE” oven.

Select “LOW TEMPERATURE” (fig.1).

Select the type of cooking from the following list and press the ✓ touch control.

- Roast veal (4h30)
- Roast beef rare (3h00)
- Roast beef well done (4h00)
- Roast pork (4h30)
- Lamb pink (3h00)
- Lamb well done (4h00)
- Chicken (6h00)
- Small fish (1h20)
- Large fish (2h10)
- Yoghurt (3h00)

Example: Yoghurt (fig.2).

Confirm your selection by pressing **OK**.

The following are now displayed: the cooking time (not modifiable) and the cooking end time that you can modify (fig.3).

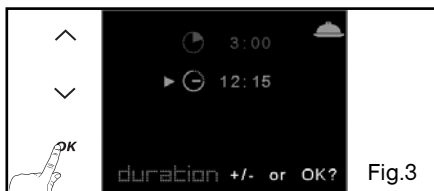

Cookware to use:

- **Leg of lamb** → Low temperatures kit
- **Small fish** → Large grill
- **Large fish** → Large grill
- **Chicken** → Spit
- **Roast beef** → Low Temperatures kit
- **Roast pork** → Low Temperatures kit
- **Roast veal** → Low Temperatures kit
- **Yoghurt** → Pots in the enamel dish

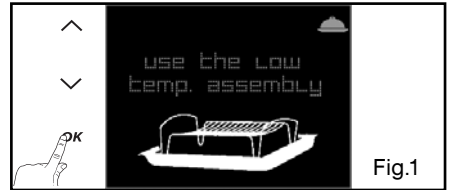

- Recommended shelf support level (fig.1).

Confirm your selection by pressing **OK**.

The oven automatically turns off, beeps for 2 minutes and tells you that it is ready.

Press **OK** to stop the beeping.

For meats, there is an automatic stay warm function (duration: 1 hour).

For yoghurts, there is a “rapid cooling” phase (duration: 1 hour).

• USING THE “INFORMATION” FUNCTION

Press **OK**.

You access the following settings with the  touch control (fig.1):

- 1 Timer
- 2 Cleaning
- 3 Time /Date
- 4 Locking the controls
- 5 Sound / Beep !
- 6 Consumption
- 7 Languages

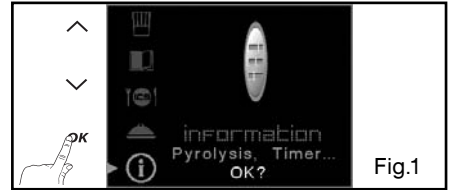

• 1 - Timer

Select the function, press **OK**.

This function is accessible as long as the oven is not in cooking mode. Enter the desired time using the touch controls + or - (fig.2).

The timer starts counting down the time as soon as you confirm it by pressing **OK**.

The beeps stop automatically after a few seconds. Press **OK** to display the clock.

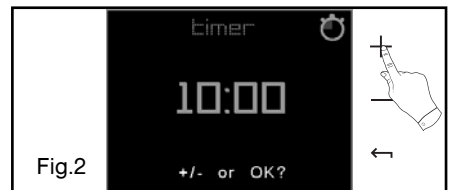

• 2 - Cleaning

Remove the grids and trays from the oven and clean any major spill residue.

Select "Cleaning" from the "Information" menu (fig.1). Your oven indicates the dirtiness of the cavity (grey zone in "DIRT") and suggests two cleaning modes:

Choose the appropriate setting:

- Pyrolysis 2h00

Pyrolysis system where the duration is preselected: it takes 2h30 (2 hours of pyro + 30 minutes cooling) and cleans the inside of the oven intensely and perfectly.

To delay the start time, select the end time and change it by entering the desired end time for the pyrolysis cycle by using the touch control + (fig.2).

Note: If you have entered details of peak and off-peak times, (see "Consumption" function) your oven recommends cleaning the oven at off-peak times to save money. However, you can change this recommendation by changing the end of pyrolysis time and starting the cleaning cycle immediately if you choose. Enter by pressing "OK".

The cleaning cycle begins. Your screen indicates: the time, the pyrolysis end time as well as the locking of the door symbolised by .

- Pyrocontrol between 1h30 and 2h15

Pyrocontrol is a pyrolysis system with a pre-set duration: it takes at least 2 hours (1h30 of pyro + 30 minutes of cooling) allowing you to save energy.

If you wish to delay the start time, select the end time and change it by entering the desired end time for the pyrolysis cycle using the touch control + (fig.3). Confirm by pressing "OK".

- End of pyrolysis

Your oven tells you when the pyrolysis cleaning cycle is finished (fig.4).

When the unlocking takes effect, you can open the door.

Simply remove the ash residue in the cavity with a damp sponge.

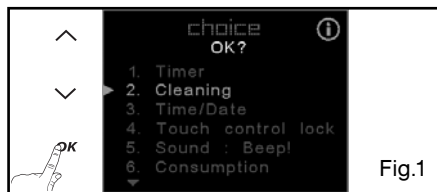

Fig.1



Fig.2

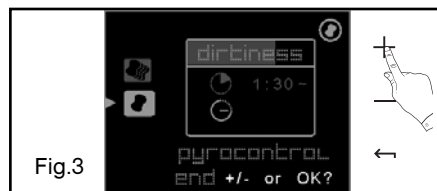

Fig.3

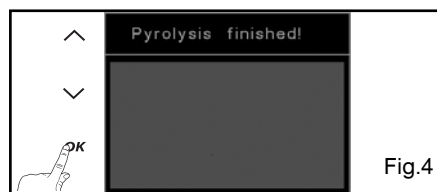

Fig.4



Warning

Before starting a pyrolysis cleaning cycle, make sure that any accessories that are not pyrolysis safe have been removed from the oven (sliding rails, baking trays, chrome-plated grills, and so on) as well as any cookware. The side grills are pyrolysis safe and may be left inside the oven during pyrolysis.

• 3 - Time / Date

See Chapter:

Using the programmer

- How to set the time (page 127).

• 4 - Lock controls

Select the function (fig.1).

Press **OK**.

Make your selection using **∨**.

Confirm your selection "yes or no" (fig.2) and press **OK**.

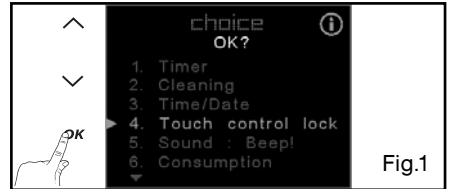

Fig.1

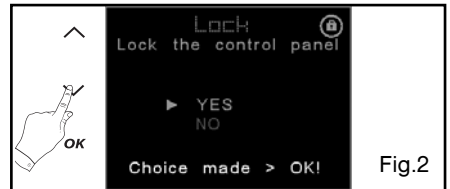

Fig.2

• 5 - Sound / Beep!

Select the function (fig.1).

Press **OK**.

Make your selection using **∨**.

Confirm your selection "yes or no" (fig.2) and press **OK**.

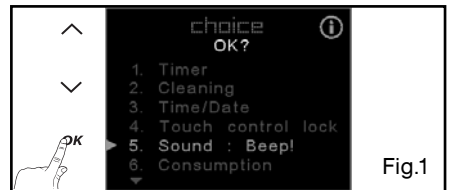

Fig.1

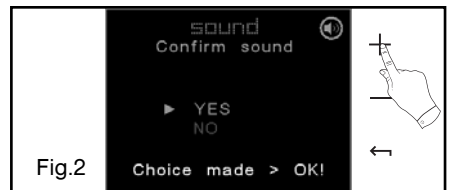

Fig.2

• 6 - Consumption

Select the function (fig.1).

Press **OK**.

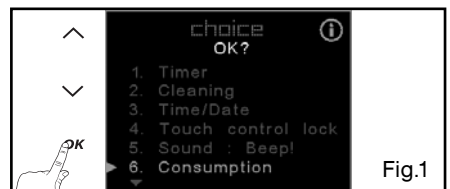

Fig.1

• 6 - Consumption

By accessing this screen, you will be able to view the energy consumption of your oven since the last time it was reset to zero.

Press OK (fig.1):

If you have an energy bill arrangement with off-peak hours, you can consult the corresponding time periods and obtain detailed information about your consumption during peak and off-peak hours.

Enter or change the periods P1 - P2 - P3 by pressing + or - (fig.2) then confirm OK.

You can enter up to three different periods

If you entered off-peak hours, whenever you program a **pyrolysis cycle**, your oven will automatically suggest that you schedule the cycle to begin cleaning during the next off-peak period.

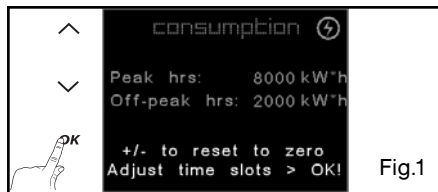

Fig.1



Fig.2

Warning

If you wish to start pyrolysis immediately, you need to cancel the off-peak programming times by pressing “-” and reducing the finish time until you see “-:-” appear.

• 7 - Languages

Select the function (fig.1).

Press OK.

Select from among the languages shown by pressing \checkmark .

Press OK.



Fig.1

• SERVICE CALLS

Any repairs that are made to your appliance must be handled by a qualified professional authorised to work on the brand. When you call, mention your appliance's complete reference (model, type, serial number). This information appears on the manufacturer's nameplate (*fig. 1*).

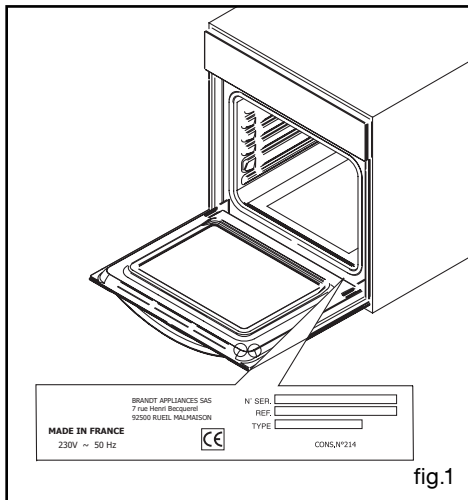

GENUINE REPLACEMENT PARTS

During maintenance work, request that only **certified genuine replacement parts are used.**

